

FUMETECH

Chemical Exhaust Fans and Fan Rotors

Fumetech is a Brisbane-based company supplying one-piece injection moulded polypropylene chemical fan rotors, PVC fans and rotor bushes to fume cupboard and fume extraction system manufacturers in Australia and New Zealand.

Fumetech products can be used for:

- Chemical storage cabinets
- Small extraction hoods
- Fume cupboards
- Chemical storage rooms
- Large exhaust hoods
- Large extraction systems

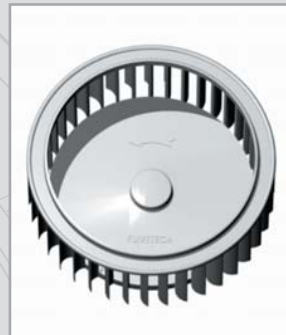

For more information please contact:

FUMETECH

Ph: +61 (0)7 3256 9612

Fax: +61 (0)7 3256 9628

Mb: +61 (0)403 363 839

Email: info@fumetech.com.au

ABN: 75 950 312 876

FUMETECH

Chemical Exhaust Fans and Fan Rotors

FUMETECH

Dimensional Data

FAN SIZE	A	B	C	D	E	F	G	H	J	K	L	M
300	315	750	795	565	390	405	295	50	25	270	315	300
250	315	650	770	550	390	380	260	50	25	240	250	300
200	250	515	685	495	380	305	235	50	25	135	250	300
150	158	400	520	404	235	285	170	50	25	125	158	168

All dimensions are in millimetres.

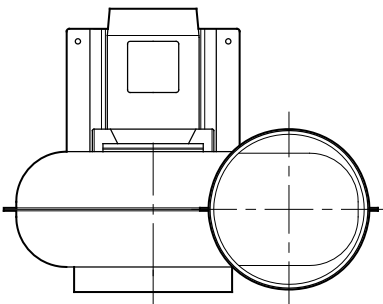
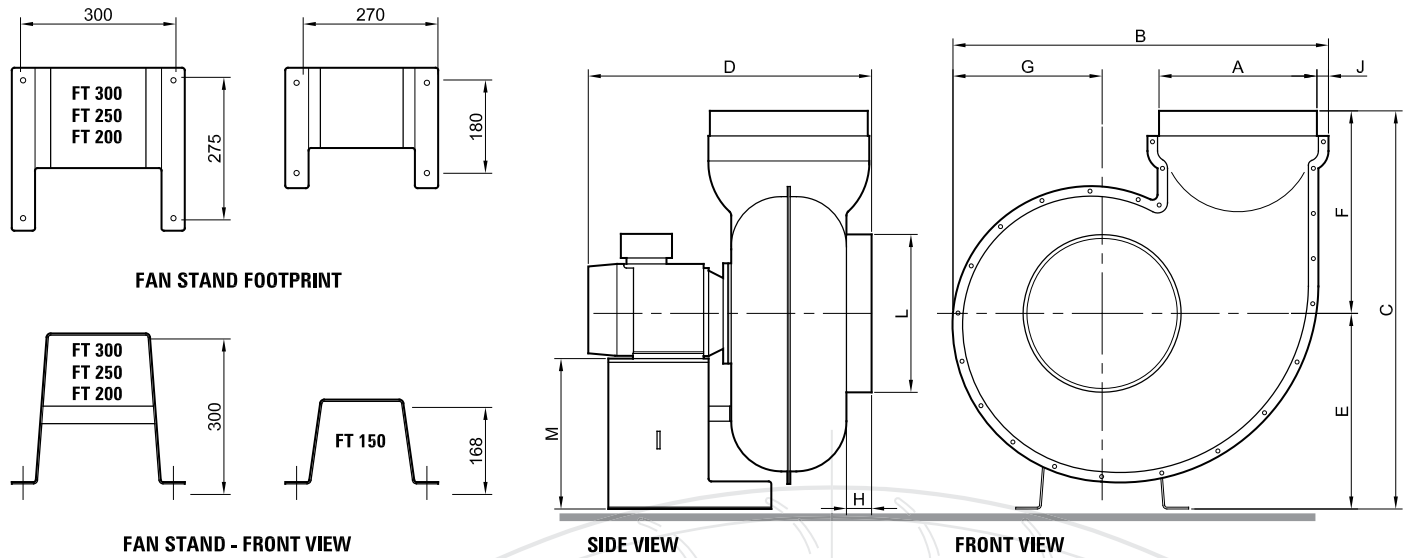

Performance Curves

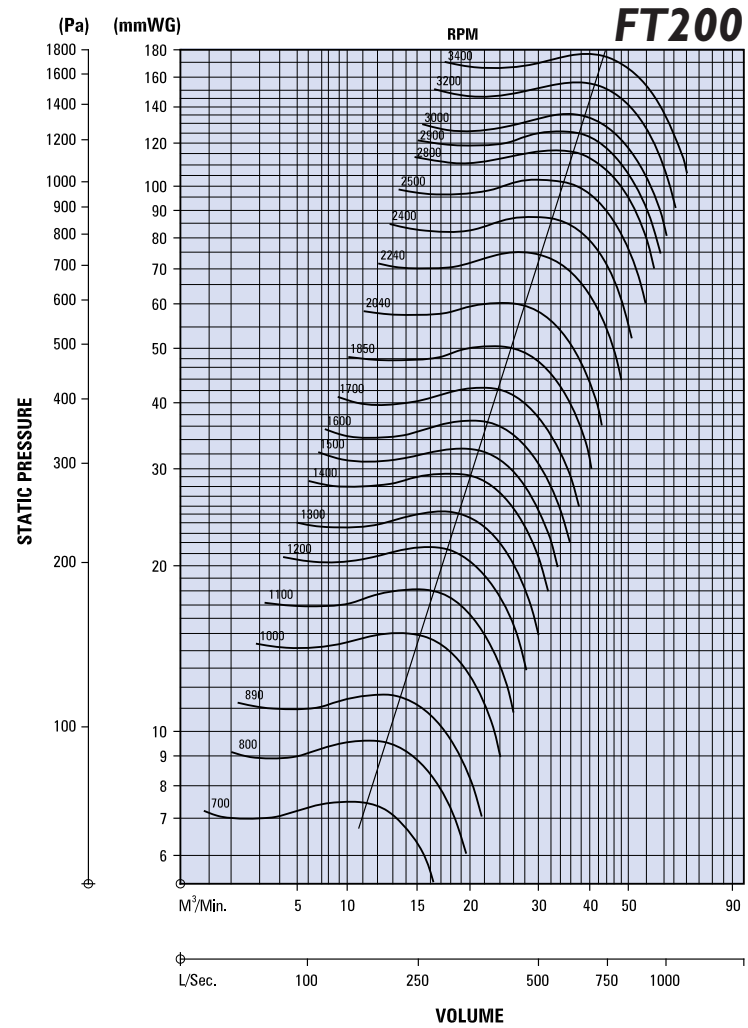
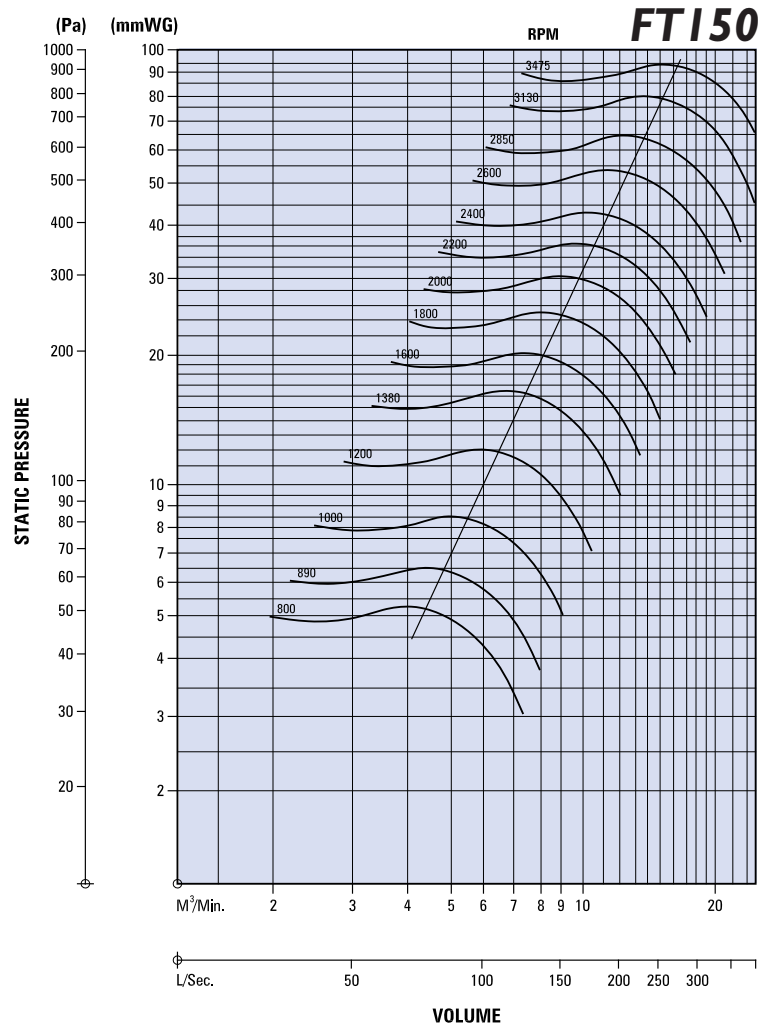

Fan Handings

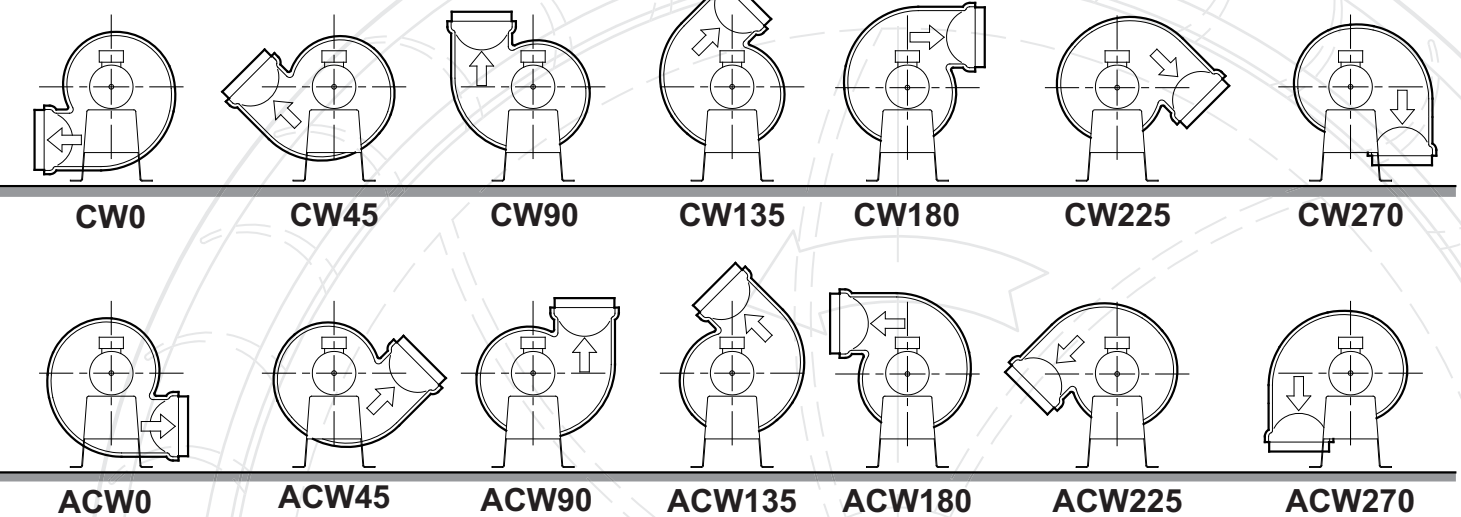

Fan Bushes

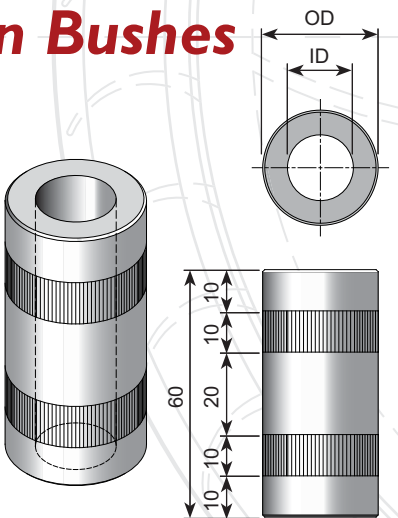

All bushes are made from mild steel and will suit most common motor sizes. Their sides are annealed to enable better gripping of the rotors.

If requested, Fumetech can press the bushes into the rotors at no extra charge.

SIZE	28 - 24mm	28 - 19mm	28mm - 5/8"
OD	28.07 ^{+0.01} / _{-0.00}	28.07 ^{+0.01} / _{-0.00}	28.07 ^{+0.01} / _{-0.00}
ID	24.20 ^{+0.15} / _{-0.00}	19.00 ^{+0.15} / _{-0.00}	5/8 inch

All dimensions are in millimetres.

